



MONTANARO F.lli

COSTRUZIONE E RIPARAZIONE MACCHINE ENOLOGICHE
MACCHINE PER CANTINE - OFFICINA E RICAMBI
DA OLTRE CINQUANT'ANNI AL SERVIZIO DELLA CLIENTELA

MONTANARO F.lli S.r.l. - Via Cav. Ottavio Riccadonna, 218 - 14053 Canelli (AT)
Tel e Fax 0141 823611 - E-mail: info@montanarofratelli.com

www.montanarofratelli.com



POMPA PERISTALTICA





MONTANARO F.lli

COSTRUZIONE E RIPARAZIONE MACCHINE ENOLOGICHE
MACCHINE PER CANTINE - OFFICINA E RICAMBI
DA OLTRE CINQUANT'ANNI AL SERVIZIO DELLA CLIENTELA

MONTANARO F.lli S.r.l. - Via Cav. Ottavio Riccadonna, 218 - 14053 Canelli (AT)
Tel e Fax 0141 823611 - E-mail: info@montanarofratelli.com

www.montanarofratelli.com



POMPA PERISTALTICA

Atta al trasferimento soffice e delicato delle uve intere, diraspate, fermentate e liquidi. Pompaggio tramite il solo schiacciamento del tubo senza nessun organo meccanico a contatto con il prodotto. Autoadescenti in profondità, funzionamento a secco, complete di variatori di giri, inversione di flusso, pressostato automatico.

A richiesta: Tramoggia con raccordi. Comando a distanza. By-Pass automatico.

POMPE PERISTALTIQUE

Apte au transport doux et léger de raisin entière, egrappée, marc et liquides. Pompage avec le seule écrasement du tuyau sans aucun organes mécaniques en contact avec le produit. Auto-amorçage en profondeur, marche à sec, complete de variateur de vitesse, inversion, pressostat automatique.

Sur demande: Conquet ave raccords. Fil de comande. By-Pass automatique.

PERISTALTIC PUMP

Suitable for a soft and delicate transport of grapes, destemmed and crushed grapes, fermented grapes, must and dense liquids. Pumping without impeller or mechanical device but only by pressing the hose with a rotative piston. Self priming, the pump can run dry, supplied with speed variator, reverse flow, regulate pressure.

On request: Feeding hopper. Remote control with cable. By-Pass automatic.

BOMBA PERISTALTICA

Con su funcionamiento simple por medio de la presión ejercitada sobre un tubo de goma, sin contacto del producto con el organo del bombeo, la bomba es apta al trasiego suave y delicado para líquidos en general, uva entera, despalillada, estrujada y uva fermentada. Autoaspirante de profundidad, funcionamiento en seco, inversion del flujo, equipada de variador de velocidad y presostato automatico.

Accesorios: Tolla con sinfin. Mando a distancia. By-Pass automatico.

PERISTALTISCHE PUMPE

Der Arbeitsprinzip diese pumpe stützt sich auf den Druck von den drehenden Walzen, die fortlaufendeinen Schlauch aus Gummi quetschen, das bewirkt den schub des Produkts nach dem Ausgang. Das ist neue weiche und leichte System für die Verlegung von Flüssigkeiten oder ganzen Trauben, abbeereene Trauben und Trester. Pumpe selbstansaugend, reversibilität des fluessen, mit stufenlosem Getriebe oder Inverter und automatische Drückregler lieferbar.

Auf Anfrage: Trichter mit schnecke. Fernsteuerung mit kable. Automatischer By-Pass.



MONTANARO F.lli

COSTRUZIONE E RIPARAZIONE MACCHINE ENOLOGICHE
MACCHINE PER CANTINE - OFFICINA E RICAMBI
DA OLTRE CINQUANT'ANNI AL SERVIZIO DELLA CLIENTELA

MONTANARO F.lli S.r.l. - Via Cav. Ottavio Riccadonna, 218 - 14053 Canelli (AT)
Tel e Fax 0141 823611 - E-mail: info@montanarofratelli.com

www.montanarofratelli.com





MONTANARO F.lli

COSTRUZIONE E RIPARAZIONE MACCHINE ENOLOGICHE
MACCHINE PER CANTINE - OFFICINA E RICAMBI
DA OLTRE CINQUANT'ANNI AL SERVIZIO DELLA CLIENTELA

MONTANARO F.lli S.r.l. - Via Cav. Ottavio Riccadonna, 218 - 14053 Canelli (AT)
Tel e Fax 0141 823611 - E-mail: info@montanarofratelli.com

www.montanarofratelli.com

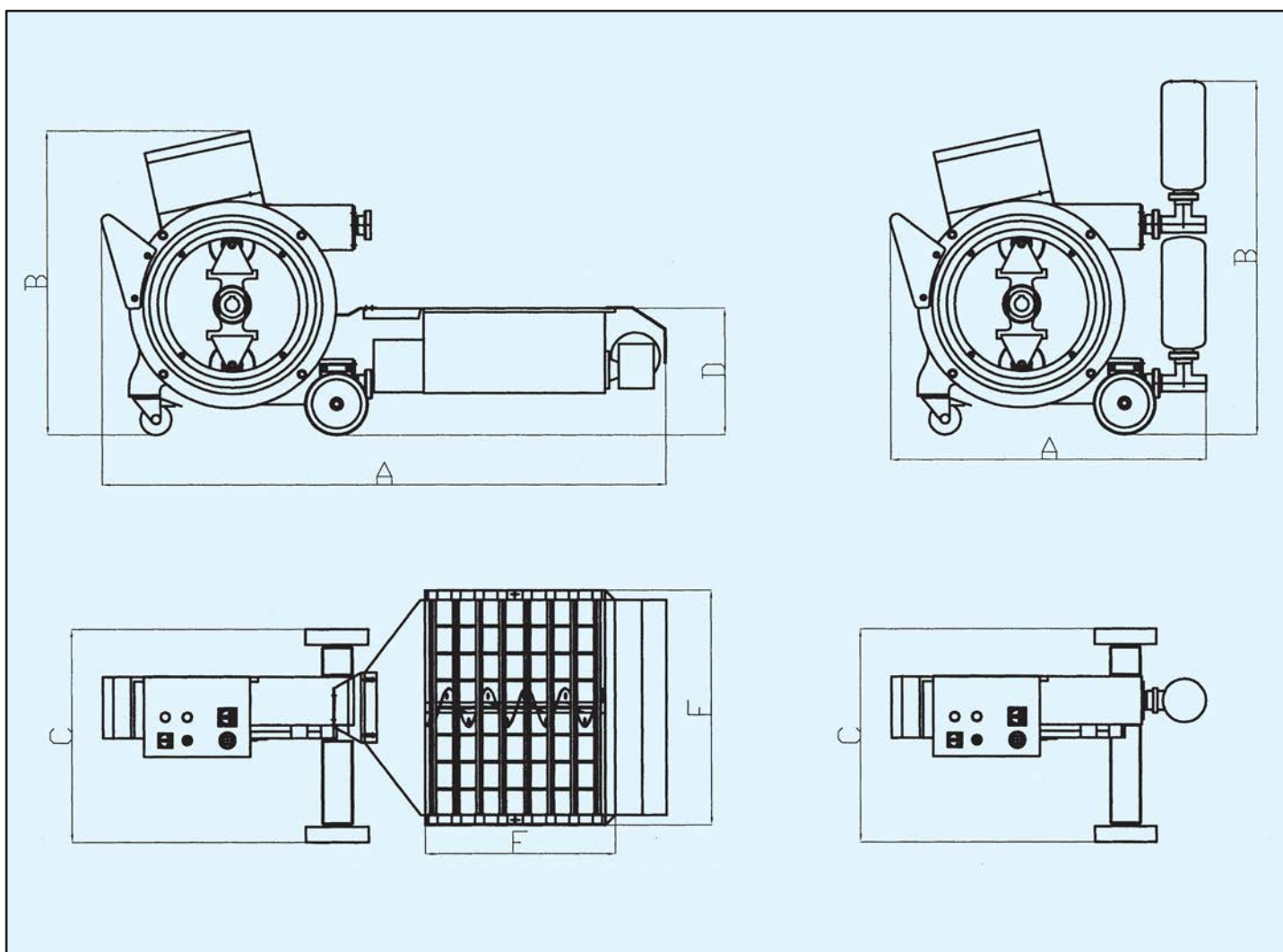

TIPO TYPE TYP	MOTORE MOTOR MOTEUR	VELOCITÀ SPEED VITESSE GESCHWINDIGKEIT VELOCIDAD	PORTATA DELIVERY DEBIT FÖRDERMENGE CAUDAL	RACCORDI FITTINGS RACCORDS ANSCHLÜSSE RACORES	DIMENSIONI mm. DIMENSIONS MASSE MEDIDAS RACORES A-B-C-D-E-F	PESO Kg. WEIGHT POIDS GEWICHT PESO
AS. 20	HP 1,0 V. 380	RPM 20-90	l/h 5-20	Ø 40	1000X800X450 HT	Kg. 65
AS. 50	HP 2,0 V. 380	RPM 7-65	l/h 5-50	Ø 40	930x1150X650 HT	Kg. 150
AS. 100	HP 4,0 V. 380	RPM 7-60	l/h 10-100	Ø 50	1200X1450X670 HT	Kg. 240
AS. 200	HP 5,5 V. 380	RPM 7-60	l/h 20-200	Ø 80	1600X1700X840 HT	Kg. 420
AS. 300	HP 10,0 V. 380	RPM 7-60	l/h 60-300	Ø 100	1800X1500X660 HT	Kg. 600
AST. 100	HP 4,0+1,0 V. 380	RPM 7-60	Ton./h 4 - 7	Ø 80	1850x970x670x420x760x640	Kg. 270
AST. 200	HP 5,5+1,0 V. 380	RPM 7-60	Ton./h 10 - 14	Ø 100	2450x1250x840x470x800x730	Kg. 460
AST. 300	HP 10,0+1,0 V. 380	RPM 7-60	Ton./h 13 - 18	Ø 100	2600x1500x660x470x900x745	Kg. 700